

## Scheda Tecnica

CODICE 11127

### MF 100/4" T

Aspiratori elicoidali da muro



## Certificazioni



CE



CCC



EAC



G-Mark



UKCA



CB TEST CERTIFICATE

## Dati tecnici e prestazionali

Corrente assorbita max (A)	0,09	Temp. ambiente max funzionamento continuativo (°C)	50
Diametro Nominale Condotta (mm)	100	Tensione (V)	220-240
Frequenza (Hz)	50	Portata max (l/s)	24
Grado Protezione IP	X4	Portata max (m³/h)	85
Isolamento	II° classe	Pressione max (mmH2O)	3
Ø Scarico (mm)	98	Pressione max (Pa)	29
Peso (Kg)	0,51	Pressione Sonora Lp [dB (A)] 3m	31
Potenza assorbita max (W)	15	RPM	2400

## Dimensioni

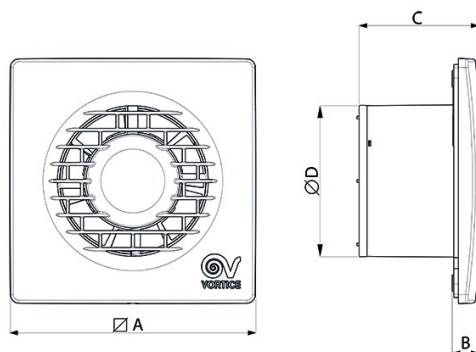

Dimensione A (mm)	159
Dimensione B (mm)	17
Dimensione C (mm)	77
Dimensione D (mm)	98

### PER INFORMAZIONI / FOR INFORMATION

#### ITALY

Pre Sales:  
prevendita@vortice-italy.com  
After Sales:  
postvendita@vortice-italy.com

#### UNITED KINGDOM & REP. OF IRELAND

Sales Dept:  
sales@vortice.ltd.uk  
Technical Dept:  
technical@vortice.ltd.uk

#### OTHER COUNTRIES

Sales Dept:  
export@vortice-italy.com  
After Sales:  
after-sales@vortice-italy.com

# Scheda Tecnica

CODICE 11127

## MF 100/4" T

Aspiratori elicoidali da muro



## Descrizione

- Costruzione in resina plastica resistente all'invecchiamento riconducibile all'esposizione al sole ("UV resistant").
- Diametro nominale 100 mm.
- Motore termicamente protetto, con albero montato su supporti a bronzine autolubrificanti, abbinato ad una girante elicoidale in materiale termoplastico con pale a profilo alare.
- Portata massima 85 m<sup>3</sup>/h.
- Equipaggiato di timer elettronico per lo spegnimento automatico del prodotto dopo un tempo prefissato impostabile, in fase di installazione, nell'intervallo 3'-20' (settaggio di default 3').
- Valvola anti-ritorno applicata alla bocca di mandata.
- Controllabile in velocità mediante regolatore Vortice.

## Curve

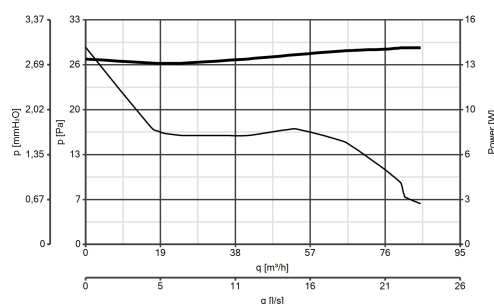

## Accessori

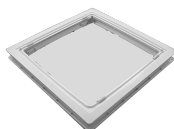

### SF 90-100

Codice 22162

### PER INFORMAZIONI / FOR INFORMATION

#### ITALY

Pre Sales:  
[prevendita@vortice-italy.com](mailto:prevendita@vortice-italy.com)  
After Sales:  
[postvendita@vortice-italy.com](mailto:postvendita@vortice-italy.com)

#### OTHER COUNTRIES

Sales Dept:  
[export@vortice-italy.com](mailto:export@vortice-italy.com)  
After Sales:  
[after-sales@vortice-italy.com](mailto:after-sales@vortice-italy.com)

#### UNITED KINGDOM & REP. OF

#### IRELAND

Sales Dept:  
[sales@vortice.ltd.uk](mailto:sales@vortice.ltd.uk)  
Technical Dept:  
[technical@vortice.ltd.uk](mailto:technical@vortice.ltd.uk)