

IVR-INOX COLLETTORE INDUSTRIALE IN ACCIAIO INOX - IVR 883



COLLETTORE INDUSTRIALE in acciaio inox AISI 304 da 1"1/2 - 2" - derivazione di mandata con valvola a sfera IVR 86A da 3/4" x 1" (per adattatore IVR 581) - derivazione di ritorno con detentore IVR 551 da 3/4" x 1" (per adattatore IVR 581) - rubinetto sfiato e carico - zanca

Stainless steel AISI 304 INDUSTRIAL MANIFOLD 1"1/2 - 2" -with ball valve IVR 86 A 3/4" x 1" (for adapter IVR 581) - lockshield valve IVR 551 3/4" x 1" (for adapter IVR 581) - draining valve - mounting bracket with insulated support and fixing kit

COLLECTEUR INDUSTRIEL en acier inox AISI 304 1"1/2 - 2" sorties avec vanne à sphère IVR 86 - 86B 3/4" Fx 1" M (pour adaptateurs IVR 581) - derivation de retour avec détendeur IVR 551 de 3/4" x 1" (pour adaptateurs IVR 581) - robinet de remplissage et de vidange - support de fixation

INDUSTRIEVERTEILER aus Edelstahl AISI 304 1"1/2-2" - Versorgungsableitung mit Kugelhahn IVR86A 3/4"x1" (für Adapter IVR581) - Rücklaufableitung mit Absperrventil IVR551 3/4"x1" (für Adapter IVR 581) - Abfluss- und Zuflussventil - Bauklammer

Colector Industrial en ACERO INOX AISI 304 DE 1 1/2" a 2" - Con válvula de esfera IVR 86 A de 3/4" x 1", para adaptador IVR 581 - Dententor IVR 551 de 3/4" x 1", para adaptador IVR 581 - Purgador y valvula de vaciado - soporte fijación

Coletor industrial em aço inox AISI 304 de 1"1/2-2" - Com válvula de esfera IVR 86A de 3/4"x1" (para adaptador IVR 581) - Detentor IVR 551 de 3/4"x1" (para adaptador IVR 581) - Válvula de Drenagem - Suporte de montagem com apoio isolado e kit de fixação

IMPIEGHI: Impianti a pannelli radianti a pavimento per applicazioni industriali (capannoni, stabilimenti, officine, supermercati), impianti antincendio, industriali di fluidi aggressivi, acqua potabile.

APPLICATION: Underfloor heating system for industrial application, fire safety system, industrial chemical, drinking water.

UTILISATION: Installations de plancher chauffant pour emplois industriels (usine, supermarchés , negoce, etc.), installation contre le incendies, application chimique, eau potable.

ANWENDUNGEN: Fußbodenheizplatten für die Industrie (Hallen, Werke, Werkstätte, Supermärkte), Feuerlösch-Anlage, aggressive Flüssigkeiten, Trinkwasser).

UTILIZACIÓN: Instalaciones de suelo radiante, supermercados, oficinas, industria química, agua potable. etc.

APLICAÇÃO: Sistema de piso radiante para aplicação industrial, sistema de segurança anti-fogo, industria química, água potável.

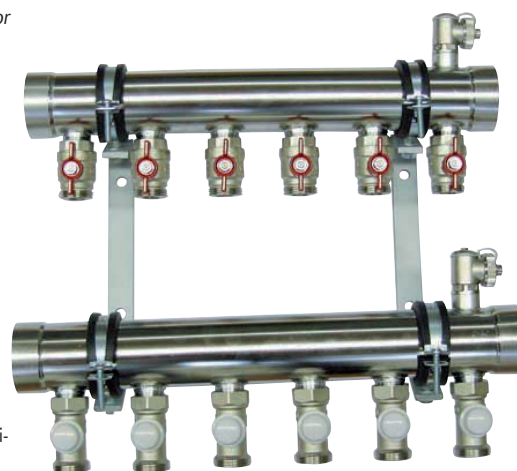

EAC

N. N.	DENOMINAZIONE PART NAME	MATERIALE MATERIAL	TRATTAMENTO TREATMENT
1	Collettore di distribuzione ritorno Manifold	Inox AISI 304	
2	Collettore di distribuzione andata Manifold	Inox AISI 304	
3	Zanca Mounting brackets	Acciaio - Steel	Zincato - Zincade plated
4	Rubinetto di scarico-carico Draining valve	Ottone - Brass CW 617N - UNI EN 12165/98	Nichelato - Nickel plated
5	Valvola a sfera Ball valve	Ottone - Brass CW 617N - UNI EN 12165/2016	Nichelato - Nickel plated
6	Detentore Lockshield	Ottone - Brass CW 617N - UNI EN 12165/98	Nichelato - Nickel plated

DATI TECNICI - TECHNICAL DATA	
Temperatura massima di esercizio Max. working temperature	100°C
Pressione massima di esercizio Max. working pressure	25 bar

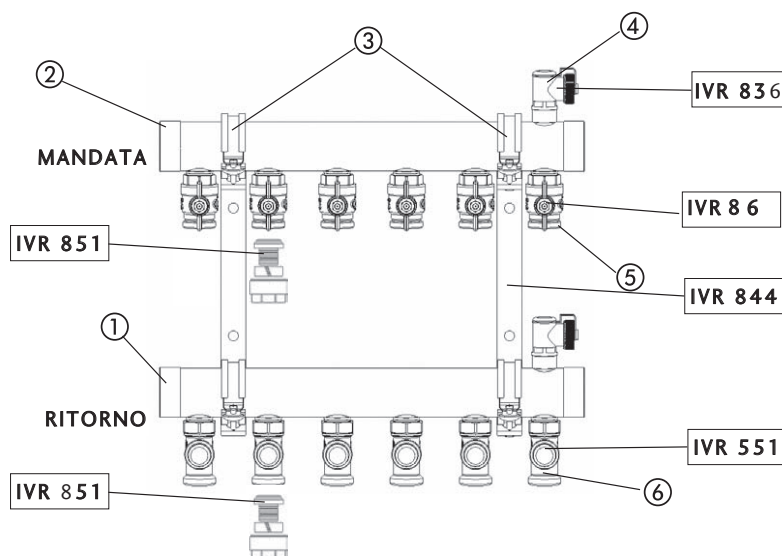

IVR-INOX COLLETTORE INDUSTRIALE IN ACCIAIO INOX - IVR 883

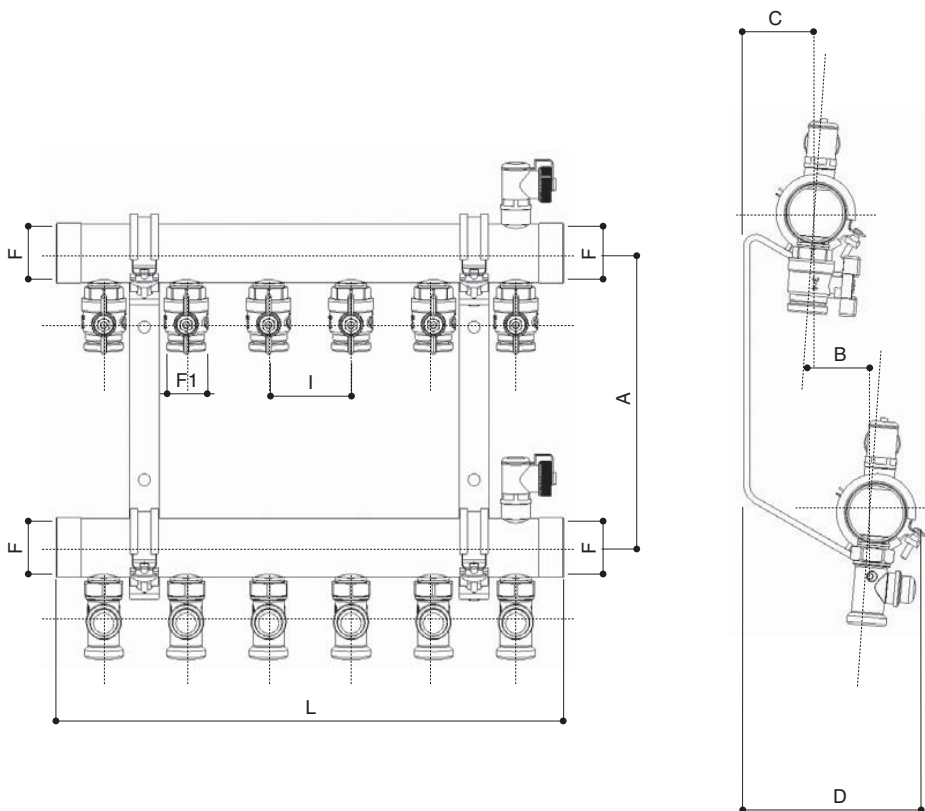

F	F1	A	B	C	I	D	L 4 Vie	L 5 Vie	L 6 vie	L 7 vie	L 8 vie	L 9 vie	L 10 vie	L 11 vie	L 12 vie	L 13 vie	L 14 vie
1"1/2	1"	250	24	60	70	125	291	361	431	501	571	641	711	781	851	921	991
2"	1"	250	24	63	70	135	299	369	439	509	579	649	719	789	859	929	999

Dimensioni in mm - Dimensions in mm

N.B. Per eventuali richieste di collettori che differiscono per numero di derivazione, interassi lunghezze, diverse da quelli indicati in tabella, vogliate contattare il ns. ufficio commerciale.
 In case of requests for manifolds differing in their number of connections, dimensions, etc., from the figures indicated in the table, please contact our Sales Office